

17190 | 17590 | 18190

PLUS

90° Shoulder milling solution

MILLING

Facing | Shouldering | Slotting



MAIN FEATURES

Coarse and fine pitch cutters suitable for all type of materials, for roughing and semi-finishing application.

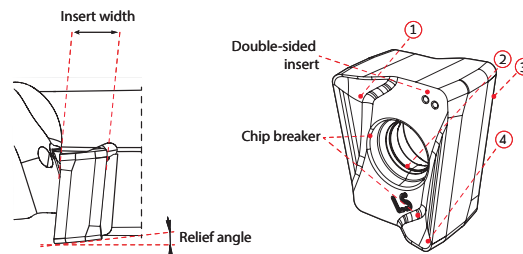
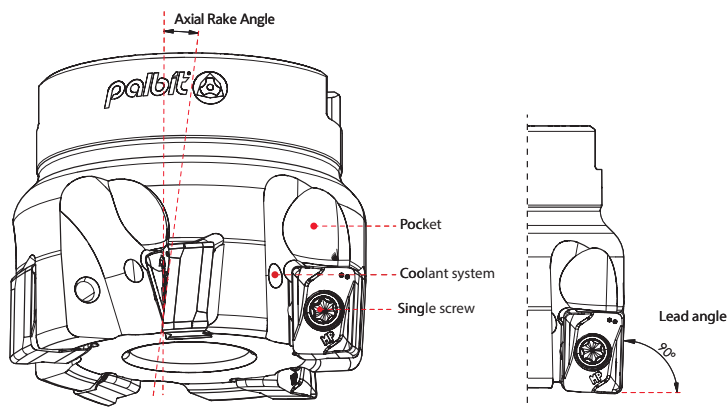

Axial Rake Angle

- For a smooth cutting;
- For low cutting forces;

True 90° wall

- 90° allows multi applications;
- Excellent for shouldering;

Single screw

- Strong clamping system;

Pocket

- Better chip evacuation due to a wide pocket;

Coolant system

- Improvement of chip control and evacuation;
- Tool life improvement due to reduced cutting temperature;

Insert Width

- High thickness allows a stronger insert;

Relief angle

- Reduce the cutting load;
- Low cutting forces;

Double-sided insert

- 4 cutting edges;
- Negative insert has a strong edge;

Chip Breaker

- Cutting load reduction due to high rake angle;
- Improvement of chip flow and evacuation in multiple applications and materials;
- New LS chip breaker (on ANHX 12) for M and S class materials;

PLUS 17190



INSERT SIZE
10 ANHX
1004

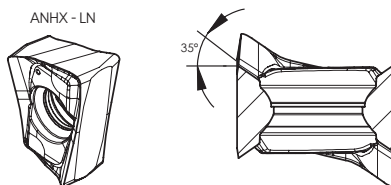
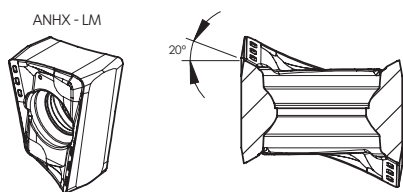
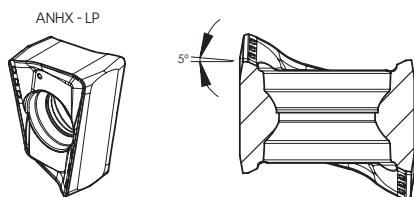

CHIP BREAKERS Quebra- aparas | Rompevirutas

Chip Breaker	Features Características Características
Geometry LP Light machining	Positive top rake angle to promote a good chip flow and reduce power consumption on low alloy steels.
Geometry LM Light machining	High positive top rate to promote a good chip flow for machining stainless steels and HRSA.
Geometry LN Light machining	High positive chip-breaker, polished for applications of non ferrous materials (aluminium).

PLUS 17190
ANHX 10

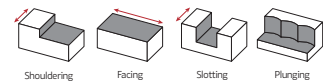

PLUS 17590

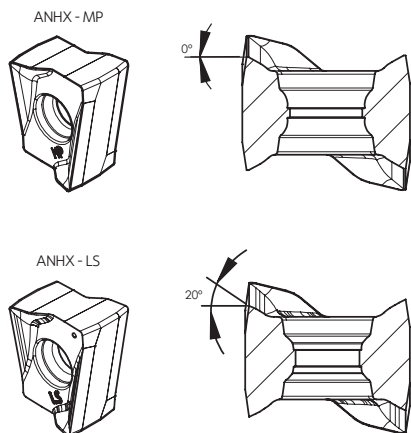

INSERT SIZE
12 ANHX
1206



CHIP BREAKERS Quebra- aparas | Rompevirutas

Chip Breaker	Features Características Características
Geometry LS Light Machining	Positive top rake angle to promote a good chip flow and reduce power consumption on stainless steel and HRSA.
Geometry MP General machining	Chip-breaker with a reinforced chanfer for general applications on steel and cast iron.

PLUS 18190

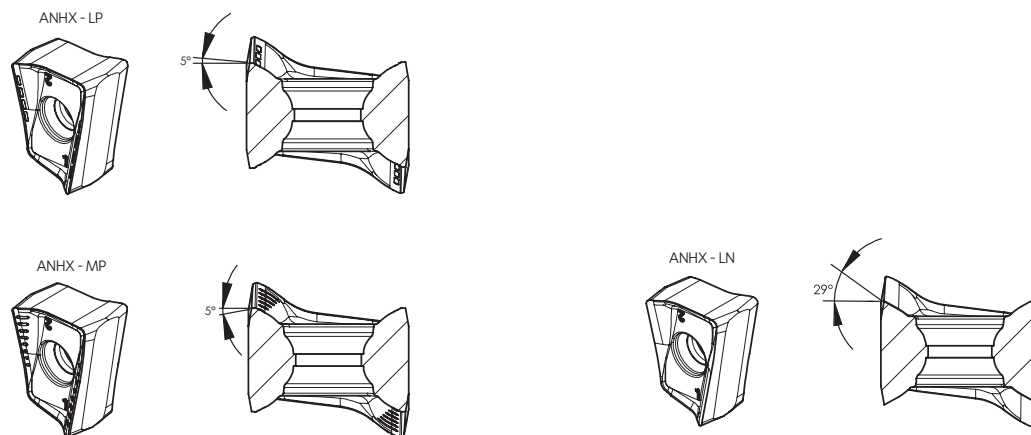

INSERT SIZE
16 ANHX
1607



CHIP BREAKERS Quebra- aparas | Rompevirutas

Chip Breaker	Features Características Características
Geometry LP Light machining	Positive top rake angle to promote a good chip flow and reduce power consumption on low alloy steels.
Geometry MP General machining	Chip-breaker with a reinforced chamfer for general applications on steel and cast iron.
Geometry LN Light machining	High positive chip-breaker, polished for applications of non ferrous materials (aluminium).



Arbor Mounting
KAPR=90° | GAMP=-7°

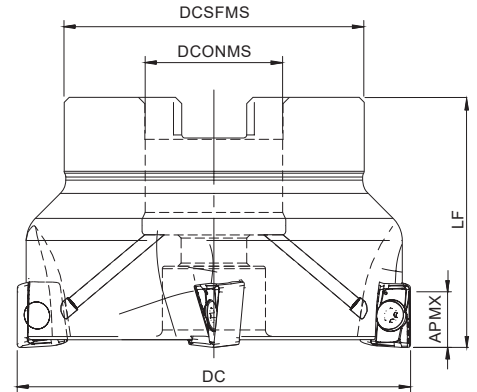

Order code Código	Reference Referência Referencia	CICT	Dimensions Dimensões Dimensiones (mm)				WT	Specifications		Insert Pastilha Inserto	Stock
			DC	DCONMS	DCSFMS	LF		Arbor Type	APMX (mm)		
181075300	040A17190-04-07-016040	4	40	16	32	40	0,21	A	9,00	ANHX 1004...	⊗
181075400	040A17190-05-07-016040	5	40	16	32	40	0,21	A	9,00	ANHX 1004...	⊗
181075500	050A17190-05-07-022040	5	50	22	42	40	0,35	A	9,00	ANHX 1004...	⊗
181075600	050A17190-07-07-022040	7	50	22	42	40	0,34	A	9,00	ANHX 1004...	⊗
181075700	063A17190-07-07-022040	7	63	22	52	40	0,55	A	9,00	ANHX 1004...	⊗
181075800	063A17190-09-07-022040	9	63	22	52	40	0,54	A	9,00	ANHX 1004...	⊗
181075900	080A17190-08-07-027050	8	80	27	60	50	1,00	B	9,00	ANHX 1004...	⊗
181076000	080A17190-10-07-027050	10	80	27	60	50	1,00	B	9,00	ANHX 1004...	⊗
181076100	100A17190-09-07-032050	9	100	32	80	50	1,80	B	9,00	ANHX 1004...	⊗
181076200	100A17190-12-07-032050	12	100	32	80	50	1,80	B	9,00	ANHX 1004...	⊗

⊗ Stock item | Produto de stock | Itens de stock

○ Available under request | Disponível sobre consulta | Disponible bajo consulta

ANHX 1004 Inserts | Pastilhas | Plaquetas



ANHX-LP

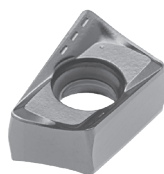

ANHX-LM

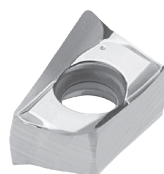

ANHX-LN

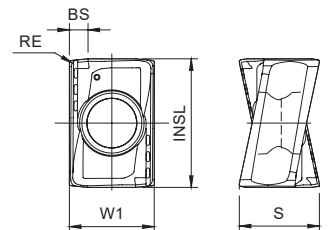

ANHX-LP | LM | LN

(1) Geometry code	(2) Grade code	P						M		K						N		S		Dimensions Dimensões Dimensiones (mm)				
		CVD		PVD				PVD		CVD		PVD				UNC		PVD						
		T9	G1	X5	T1	P4	G6	X9	G6	T9	G1	X5	T1	P4	G6	10	X9	G6	W1	S	INSL	RE	BS	
1111652	ANHX 100405 PNR-LP			⊗	⊗	⊗		○				⊗	⊗	⊗		○		6,60	6,20	10,00	0,50	0,85		
1112106	ANHX 100408 PNR-LP				⊗	⊗	○					⊗	⊗	○		○		6,60	6,20	10,00	0,80	0,60		
1111908	ANHX 100412 PNR-LP				⊗	⊗						⊗	⊗					6,60	6,20	10,00	1,20	0,30		
1112021	ANHX 100416 PNER-LP				○							○						6,60	6,20	10,00	1,60	0,20		
1112513	ANHX 100402 PNER-LM				○			○				○				○		6,60	6,20	10,00	0,20	1,10		
1112005	ANHX 100405 PNER-LM				⊗	⊗	⊗	⊗	⊗			⊗	⊗	⊗		⊗	⊗	6,60	6,20	10,00	0,50	0,85		
1112162	ANHX 100408 PNER-LM	○			⊗	⊗	⊗	⊗	⊗	○		⊗	⊗	⊗		⊗	⊗	6,60	6,20	10,00	0,80	0,60		
1112103	ANHX 100412 PNER-LM				⊗	⊗	⊗	⊗	⊗			⊗	⊗	⊗		⊗	⊗	6,60	6,20	10,00	1,20	0,30		
1111997	ANHX 100405 PNFR-LN															⊗		6,60	6,20	10,00	0,50	0,85		
1112102	ANHX 100412 PNR-LN															⊗		6,60	6,20	10,00	1,20	0,30		

⊗ First choice | Primeira opção | 1ª opción

⊗ Stock item | Produto de stock | Itens de stock

○ Available under request | Disponível sobre consulta
Disponible bajo consulta

Insert order code = (1) Geometry Code + (2) Grade Code

PLUS 17190
ANHX 10

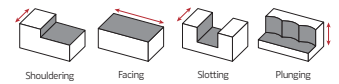

Weldon Shank
KAPR=90° | GAMP=-7° (-6°*)

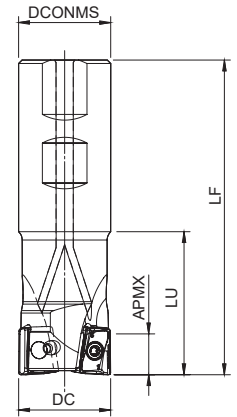

Order code Código	Reference Referência Referencia	CICT	Dimensions Dimensões Dimensiones (mm)				WT	Specifications	Insert Pastilha Inserto	Stock
			DC	DCONMS	LF	LU		APMX (mm)		
181075000	014W17190-01-06-016090*	1	14	16	90	23	0,188	9,00	ANHX 1004...	☺
181101400	016W17190-02-06-016090*	2	16	16	90	25	0,123	9,00	ANHX 1004...	☺
181096800	016W17190-02-06-016150*	2	16	16	150	25	0,190	9,00	ANHX 1004...	☺
181075200	018W17190-02-06-016090*	2	18	16	90	23	0,125	9,00	ANHX 1004...	☺
181071400	020W17190-02-06-020100*	2	20	20	100	30	0,210	9,00	ANHX 1004...	☺
181071500	020W17190-03-06-020100*	3	20	20	100	30	0,206	9,00	ANHX 1004...	☺
181074400	025W17190-02-06-025115*	2	25	25	115	35	0,391	9,00	ANHX 1004...	☺
181074500	025W17190-03-06-025115*	3	25	25	115	35	0,387	9,00	ANHX 1004...	☺
181074600	032W17190-03-06-032125*	3	32	32	125	40	0,701	9,00	ANHX 1004...	☺
181074700	032W17190-04-06-032125*	4	32	32	125	40	0,698	9,00	ANHX 1004...	☺
181074800	040W17190-04-07-032130	4	40	32	130	40	0,780	9,00	ANHX 1004...	☺
181074900	040W17190-05-07-032130	5	40	32	130	40	0,777	9,00	ANHX 1004...	☺

☺ Stock item | Produto de stock | Itens de stock

○ Available under request | Disponível sobre consulta | Disponible bajo consulta

SPARE PARTS Acessórios | Repuestos

Cutter DC	Insert Screw	Key (Torx)	Order separately		Order separately	
			Key (Torx - Nm)	Torque Value	Screw	DIN 6368 Wrench
W17190 - 14 - 40	P0300800	XT09	DT0914	1,4	-	-
A17190 - 40 - 63	P0300800	XT09	DT0914	1,4	-	-
A17190 - 80	P0300800	XT09	DT0914	1,4	J0123510	SD6368-12
A17190 - 100	P0300800	XT09	DT0914	1,4	J0164110	SD6368-16

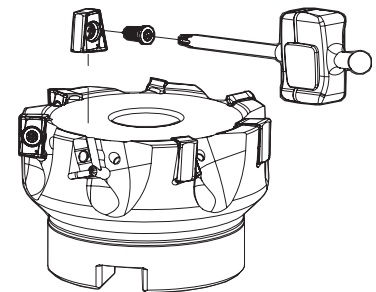

GRADES SELECTION GUIDE Guia para selecção de graus | Tabla para selección de calidades

ISO	PSM	Material	HB (Brinell)	Grades						
				← Wear Resistance				Toughness →		
				PH0910	PHP910	PHP920	PHP930	PHH930	PHS740	PH7740
P	1	Unalloyed Steel	125-220	●	●	●	●		●	●
	2	Low-Alloyed Steel	220-280		●	●	●		●	●
	3	High-Alloyed Steel	280-380		●	●	●		●	●
M	4	SS - Ferritic / Martensitic	200-330					●		●
	5	SS - Austenitic	200-330					●		●
	6	SS - Austenitic-ferritic (Duplex)	230-260					●		●
K	7	Malleable Cast Iron	130-230		●	●	●		●	●
	8	Grey Cast Iron	180-245		●	●	●		●	●
	9	Nodular Cast iron	160-250		●	●	●		●	●
N	10	Aluminium and Non Ferrous	30-130	●						
S	11	Heat Resistant Super Alloys	200-320					●		●

Good Conditions
 Average Conditions
 Difficult Conditions

RECOMMENDED CUTTING CONDITIONS Condições de corte recomendadas | Condiciones de corte recomendables

ISO	PSM	Material	HB (Brinell)	Vc (m/min)							Feed fz (mm/t)		
				← Wear Resistance				Toughness →					
				PH0910	PHP910	PHP920	PHP930	PHH930	PHS740	PH7740	ANH... LP	ANH... LM	ANH... LN
P	1	Unalloyed Steel	125-220	-	180-250	180-250	160-230	-	140-220	140-200	0,08-0,20	0,08-0,20	-
	2	Low-Alloyed Steel	220-280	-	160-240	160-230	140-210	-	120-200	130-180	0,08-0,20	0,08-0,15	-
	3	High-Alloyed Steel	280-380	-	140-230	140-220	120-200	-	100-190	100-170	0,08-0,15	0,08-0,15	-
M	4	SS - Ferritic / Martensitic	200-330	-	-	-	-	140-210	-	130-180	-	0,08-0,20	-
	5	SS - Austenitic	200-330	-	-	-	-	120-170	-	110-160	-	0,08-0,15	-
	6	SS - Austenitic-ferritic (Duplex)	230-260	-	-	-	-	100-150	-	90-150	-	0,08-0,15	-
K	7	Malleable Cast Iron	130-230	-	180-300	160-270	150-250	-	160-300	140-220	0,08-0,25	0,08-0,20	-
	8	Grey Cast Iron	180-245	-	160-250	140-250	140-230	-	150-260	120-210	0,08-0,20	0,08-0,20	-
	9	Nodular Cast iron	160-250	-	150-210	120-210	100-200	-	80-220	100-190	0,08-0,20	0,08-0,15	-
N	10	Aluminium and Non Ferrous	30-130	100-2000	-	-	-	-	-	-	-	-	0,08-0,20
S	11	Heat Resistant Super Alloys	200-320	-	-	-	-	30-110	-	30-100	-	0,08-0,15	-

(Note 1) Cutting conditions $a_e/D_c=70\%$.

(Note 2)

Operation	a_e	Vc & fz	AP (mm)
Slotting	100%	<20%	2,0-3,5
Shouldering	<50%	>8%	3,0-6,0
	≤25%	>12%	6,0-8,5

(Note 3)

It's possible to occur vibrations in certain cases. Please reduce depth of cut and / or reduce cutting conditions in following cases:

- When using long shank;
- When using long tool overhang with arbor type;
- When application has poor clamping rigidity or when using a low rigidity machine.

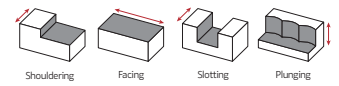

CHIP BREAKER SELECTION GUIDE Guia para aplicações do quebra- aparas | Guía para aplicación del rompevirutas

ISO	PSM	Material	HB (Brinell)	Chip breaker application	
				1 st choice	Difficult Operations
P	1	Unalloyed Steel	125-220	ANHX 10... LM	ANHX 10... LP
	2	Low-Alloyed Steel	220-280	ANHX 10... LM	ANHX 10... LP
	3	High-Alloyed Steel	280-380	ANHX 10... LM	ANHX 10... LP
M	4	SS - Ferritic / Martensitic	200-330	ANHX 10... LM	-
	5	SS - Austenitic	200-330	ANHX 10... LM	-
	6	SS - Austenitic-ferritic (Duplex)	220-260	ANHX 10... LM	-
K	7	Malleable Cast Iron	130-230	ANHX 10... LM	ANHX 10... LP
	8	Grey Cast Iron	180-245	ANHX 10... LM	ANHX 10... LP
	9	Nodular Cast iron	160-250	ANHX 10... LP	-
N	10	Aluminium and Non Ferrous	30-130	ANHX 10... LN	-
S	11	Heat Resistant Super Alloys	200-320	ANHX 10... LM	-

PLUNGING Mergulho | Plunge

L ≤ 3DC	L > 3DC	S max.
f _z (mm/t)		
0,10-0,20	0,10-0,14	$S_{max} = \sqrt{DC \cdot Dr} - Dr^2$

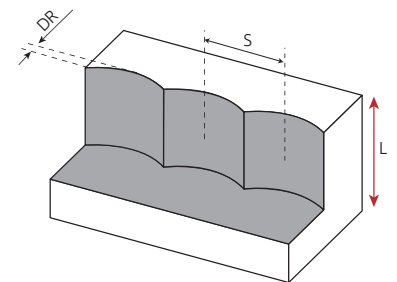

S max and DR corresponding cutting diameter DC (mm)											
DR (mm)	DC (mm)										
	14	16	18	20	25	32	40	50	63	80	100
1,0	3,6	3,9	4,1	4,4	4,9	5,6	6,2	7,0	7,9	8,9	9,9
2,0	4,9	5,3	5,7	6,0	6,8	7,7	8,7	9,8	11,0	12,5	14,0
3,0	5,7	6,2	6,7	7,1	8,1	9,3	10,5	11,9	13,4	15,2	17,1

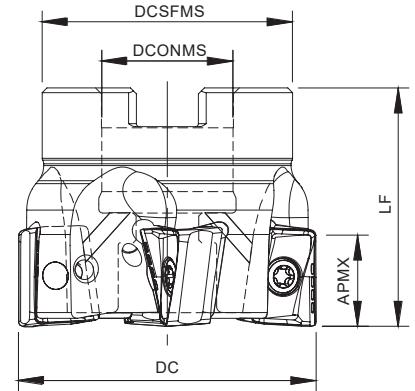
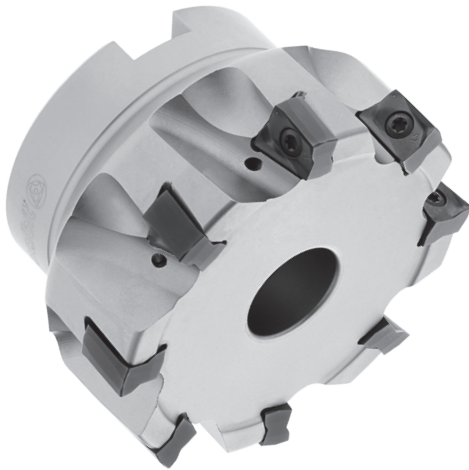

Arbor Mounting
KAPR=90° | GAMP=-6°

Order code Código	Reference Referência Referencia	CICT	Dimensions Dimensões Dimensiones (mm)				WT	Specifications		Insert Pastilha Inserto	Stock
			DC	DCONMS	DCSFMS	LF		Arbor Type	APMX (mm)		
181116400	040A17590-04-06-016040	4	40	16	32	40	0,17	A	11,00	ANHX 1206...	⊗
181114500	050A17590-05-06-022040	5	50	22	42	40	0,30	A	11,00	ANHX 1206...	⊗
181115900	050A17590-06-06-022040	6	50	22	42	40	0,30	A	11,00	ANHX 1206...	⊗
181116500	063A17590-05-06-022040	5	63	22	52	40	0,55	A	11,00	ANHX 1206...	⊗
181116600	063A17590-07-06-022040	7	63	22	52	40	0,52	A	11,00	ANHX 1206...	⊗
181116700	080A17590-08-06-027050	8	80	27	60	50	1,10	A	11,00	ANHX 1206...	⊗
181116800	080A17590-10-06-027050	10	80	27	60	50	1,10	A	11,00	ANHX 1206...	○
181116900	100A17590-12-06-032050	12	100	32	80	50	1,65	B	11,00	ANHX 1206...	⊗
181117000	125A17590-14-06-040063	14	125	40	90	63	3,16	B	11,00	ANHX 1206...	⊗

⊗ Stock item | Produto de stock | Itens de stock

○ Available under request | Disponível sobre consulta | Disponible bajo consulta

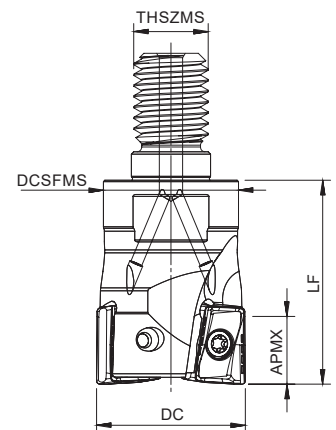

Threaded Coupling
KAPR=90° | GAMP=-6°

Order code Código	Reference Referência Referencia	CICT	Dimensions Dimensões Dimensiones (mm)				WT	Specifications	Insert Pastilha Inserto	Stock
			DC	THSZMS	DCSFMS	LF		APMX (mm)		
181117100	025R17590-02-06-M12035	2	25	M12	21	35	0,09	11,00	ANHX 1206...	⊗
181117200	032R17590-03-06-M16043	3	32	M16	29	43	0,20	11,00	ANHX 1206...	⊗
181117300	042R17590-04-06-M16043	4	42	M16	29	43	0,26	11,00	ANHX 1206...	○

⊗ Stock item | Produto de stock | Itens de stock

○ Available under request | Disponível sobre consulta | Disponible bajo consulta

PLUS 17590
ANHX 12

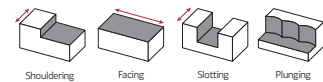

Weldon Shank
KAPR=90° | GAMP=-6°

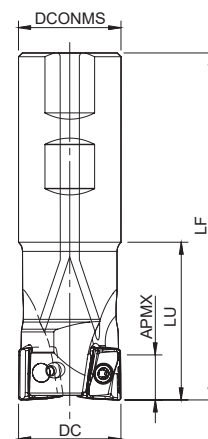

Order code Código	Reference Referência Referencia	CICT	Dimensions Dimensões Dimensiones (mm)				WT	Specifications	Insert Pastilha Inserto	Stock
			DC	DCONMS	LF	LU		APMX (mm)		
181116000	025W17590-02-06-025110	2	25	25	110	35	0,37	11,00	ANHX 1206...	☺
181120600	032W17590-03-06-032150	3	32	32	150	35	0,84	11,00	ANHX 1206...	☺
181116100	040W17590-04-06-032150	4	40	32	150	40	0,88	11,00	ANHX 1206...	☺

☺ Stock item | Produto de stock | Itens de stock

○ Available under request | Disponível sobre consulta | Disponible bajo consulta



Cylindrical Shank
KAPR=90° | GAMP=-6°

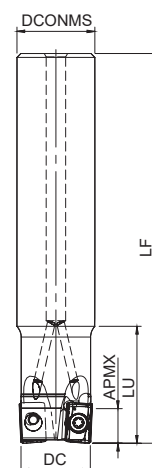

Order code Código	Reference Referência Referencia	CICT	Dimensions Dimensões Dimensiones (mm)				WT	Specifications	Insert Pastilha Inserto	Stock
			DC	DCONMS	LF	LU		APMX (mm)		
181116300	026E17590-02-06-025200	2	26	25	200	40	0,66	11,00	ANHX 1206...	☺
181116200	033E17590-03-06-032250	3	33	32	250	40	1,40	11,00	ANHX 1206...	☺

☺ Stock item | Produto de stock | Itens de stock

○ Available under request | Disponível sobre consulta | Disponible bajo consulta

SPARE PARTS Acessórios | Repuestos

Cutter DC	Insert Screw	Key (Torx)	Order separately	
			Key (Torx - Nm)	Torque Value
A17590 - 40 - 100	P0350904	XT10	DT1020	2,0
A17590 - 125	P0350904	PT10	DT1020	2,0
R17590 - 25 - 42	P0350904	XT10	DT1020	2,0
W17590 - 25-40	P0350904	XT10	DT1020	2,0
E17590 - 26 - 33	P0350904	XT10	DT1020	2,0

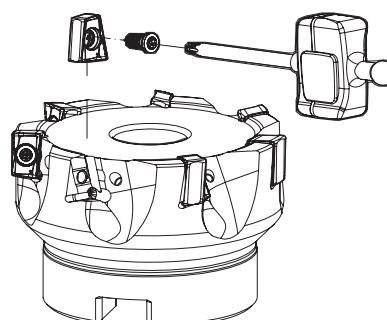

ANHX 1206... Inserts | Pastilhas | Plaquetas

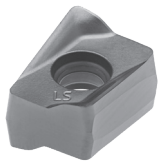

ANHX-LS



ANHX-MP

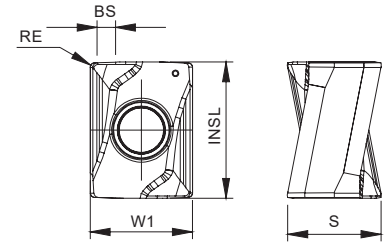

ANHX-LS | MP

		P					M			K					S			Dimensions Dimensões Dimensiones (mm)					
		CVD		PVD			PVD			CVD		PVD			PVD								
(1)	(2) Grade code	T9	T1	P3	P4	G6	P3	X9	G6	T9	L6	T1	P3	P4	G6	P3	X9	G6	W1	S	INSL	RE	BS
Geometry code	ISO Reference	PHS740	PHP920	PH7930	PHP930	PH7740	PH7930	PHH930	PH7740	PHS740	PH5320	PHP920	PH7930	PHP930	PH7740	PH7930	PHH930	PH7740					
1112474	ANHX 120604 PNER-LS		⊗		○	⊗						⊗		⊗	⊗		⊗		9,00	8,30	12,00	0,40	1,60
1112237	ANHX 120608 PNER-LS		⊗		⊗	⊗						⊗		⊗	⊗		⊗		9,00	8,30	12,00	0,80	1,20
1112429	ANHX 120616 PNER-LS		⊗		○	⊗						⊗		○	⊗		⊗		9,00	8,30	12,00	1,60	0,40
1112473	ANHX 120604 PNSR-MP		⊗			⊗					⊗	⊗			⊗				9,00	8,30	12,00	0,40	1,60
1112238	ANHX 120608 PNSR-MP	⊗	⊗			⊗				⊗	⊗	⊗			⊗				9,00	8,30	12,00	0,80	1,20
1112430	ANHX 120616 PNSR-MP		⊗			⊗					⊗	⊗			⊗				9,00	8,30	12,00	1,60	0,40
1113476	ANHX 120620 PNSR-MP		○								○								9,00	8,30	12,00	2,00	-

⊗ First choice | Primeira opção | 1ª opción ⊗ Stock item | Produto de stock | Itens de stock ○ Available under request | Disponível sobre consulta / Disponible bajo consulta Insert order code = (1) Geometry Code + (2) Grade Code

RECOMMENDED CUTTING CONDITIONS Condições de corte recomendadas | Condiciones de corte recomendables

ISO	PSM	Material	HB (Brinell)	Vc (m/min)							Feed fz (mm/t)	
				← Wear Resistance				Toughness →			ANHX 12... LS	ANHX 12... MP
				PH5320	PHP920	PHH930	PHP930	PH7930	PHS740	PH7740		
P	1	Unalloyed Steel	125-220	-	180-250	-	160-220	160-220	140-220	140-200	0,08-0,20	0,08-0,30
	2	Low-Alloyed Steel	220-280	-	160-230	-	140-200	140-200	120-200	130-180	0,08-0,20	0,08-0,25
	3	High-Alloyed Steel	280-380	-	140-220	-	120-190	120-190	100-190	100-170	0,08-0,15	0,08-0,20
M	4	SS - Ferritic / Martensitic	200-330	-	-	140-210	-	140-200	-	130-180	0,08-0,20	-
	5	SS - Austenitic	200-330	-	-	120-170	-	120-160	-	110-160	0,08-0,15	-
	6	SS - Austenitic-ferritic (Duplex)	230-260	-	-	100-150	-	100-140	-	90-150	0,08-0,15	-
K	7	Malleable Cast Iron	130-230	150-280	160-270	-	150-240	150-240	160-300	140-220	0,08-0,20	0,08-0,30
	8	Grey Cast Iron	180-245	160-320	140-250	-	140-230	140-230	150-260	120-210	0,08-0,20	0,08-0,25
	9	Nodular Cast iron	160-250	100-190	120-210	-	100-190	100-190	80-220	100-190	0,08-0,20	0,08-0,20
S	11	Heat Resistant Super Alloys	200-320	-	-	30-110	-	30-100	-	30-100	0,07-0,10	-

(Note 1) Cutting conditions $a_e/D_c=70\%$.

(Note 2)

Operation	a_e	Vc & fz	AP (mm)
Slotting	100%	<20%	2,5-4,0
Shouldering	<50%	>8%	4,0-7,0
	≤25%	>12%	7,0-10,0

(Note 3) It's possible to occur vibrations in certain cases. Please reduce depth of cut and / or reduce cutting conditions in following cases:
 - When using long shank;
 - When using long tool overhang with arbor type;
 - When application has poor clamping rigidity or when using a low rigidity machine.

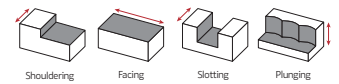

GRADES SELECTION GUIDE Guia para selecção de graus | Tabla para selección de calidades

ISO	PSM	Material	HB (Brinell)	Grades					
				← Wear Resistance			Toughness →		
				PH5320	PHP920	PHH930	PH7930	PHS740	PH7740
P	1	Unalloyed Steel	125-220	●	●	●	●	●	●
	2	Low-Alloyed Steel	220-280		●		●	●	●
	3	High-Alloyed Steel	280-380		●		●	●	●
M	4	SS - Ferritic / Martensitic	200-330			●	●		●
	5	SS - Austenitic	200-330			●	●		●
	6	SS - Austenitic-ferritic (Duplex)	230-260			●	●		●
K	7	Malleable Cast Iron	130-230	●	●		●	●	●
	8	Grey Cast Iron	180-245	●	●		●	●	●
	9	Nodular Cast iron	160-250	●	●		●	●	●
S	11	Heat Resistant Super Alloys	200-320				●		●

● Good Conditions
 ● Average Conditions
 ● Difficult Conditions

CHIP BREAKER SELECTION GUIDE Guia para aplicações do quebra- aparas | Guía para aplicación del rompevirutas

ISO	PSM	Material	HB (Brinell)	Chip breaker application	
				1 st choice	Difficult Operations
P	1	Unalloyed Steel	125-220	ANHX 12... LS	ANHX 12... MP
	2	Low-Alloyed Steel	220-280	ANHX 12... MP	-
	3	High-Alloyed Steel	280-380	ANHX 12... MP	-
M	4	SS - Ferritic / Martensitic	200-330	ANHX 12... LS	-
	5	SS - Austenitic	200-330	ANHX 12... LS	-
	6	SS - Austenitic-ferritic (Duplex)	220-260	ANHX 12... LS	-
K	7	Malleable Cast Iron	130-230	ANHX 12... LS	ANHX 12... MP
	8	Grey Cast Iron	180-245	ANHX 12... MP	-
	9	Nodular Cast iron	160-250	ANHX 12... MP	-
S	11	Heat Resistant Super Alloys	200-320	ANHX 12... LS	-

PLUNGING Mergulho | Plunge

L ≤ 3DC	L > 3DC	S max.
f _z (mm/t)		
0,10-0,20	0,10-0,14	$S_{max} = \sqrt{DC \cdot Dr - Dr^2}$

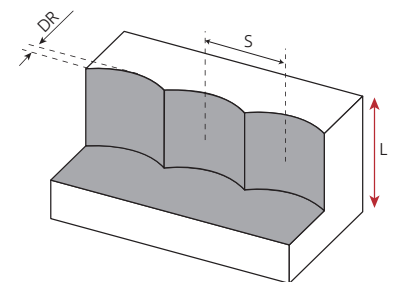

S max and DR corresponding cutting diameter DC (mm)							
DR (mm)	DC (mm)						
	32	40	50	63	80	100	125
1,0	5,6	6,2	7,0	7,9	8,9	9,9	11,1
2,0	7,7	8,7	9,8	11,0	12,5	14,0	15,7
3,0	9,3	10,5	11,9	13,4	15,2	17,1	19,1

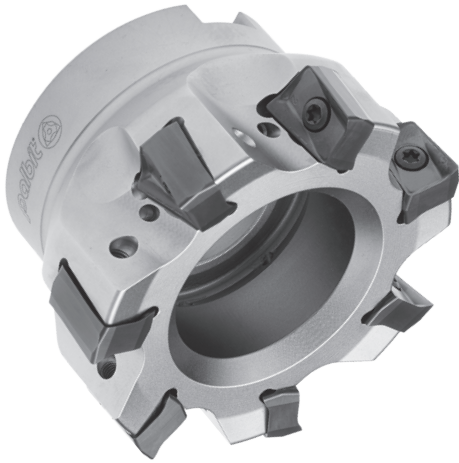

Arbor Mounting
KAPR=90° | GAMP=-4°

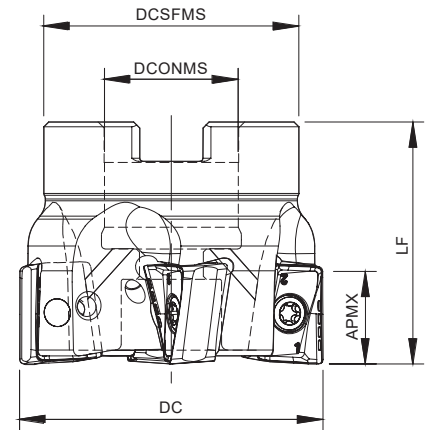

Order code Código	Reference Referência Referencia	CICT	Dimensions Dimensões Dimensiones (mm)				WT	Specifications		Insert Pastilha Inserto	Stock
			DC	DCONMS	DCSFMS	LF		Arbor Type	APMX (mm)		
181067600	050A18190-03-04-022040	3	50	22	42	40	0,28	A	15,0	ANHX 1607...	☺
181067700	050A18190-04-04-022040	4	50	22	42	40	0,27	A	15,0	ANHX 1607...	☺
181067800	063A18190-04-04-022040	4	63	22	52	40	0,51	A	15,0	ANHX 1607...	☺
181067900	063A18190-06-04-022040	6	63	22	52	40	0,48	A	15,0	ANHX 1607...	☺
181068000	080A18190-05-04-027050	5	80	27	60	50	0,88	B	15,0	ANHX 1607...	☺
181051800	080A18190-07-04-027050	7	80	27	60	50	0,36	B	15,0	ANHX 1607...	☺
181068100	100A18190-05-04-032050	5	100	32	80	50	1,60	B	15,0	ANHX 1607...	☺
181068200	100A18190-08-04-032050	8	100	32	80	50	1,59	B	15,0	ANHX 1607...	☺
181068300	125A18190-07-04-040063	7	125	40	90	63	2,93	B	15,0	ANHX 1607...	☺
181068400	125A18190-10-04-040063	10	125	40	90	63	2,89	B	15,0	ANHX 1607...	☺
181068500	160A18190-08-04-U040063	8	160	40	110	63	4,29	C	15,0	ANHX 1607...	☺
181068600	160A18190-12-04-U040063	12	160	40	110	63	4,29	C	15,0	ANHX 1607...	☺

☺ Stock item | Produto de stock | Itens de stock

○ Available under request | Disponível sobre consulta | Disponible bajo consulta



Threaded Coupling
KAPR=90° | GAMP=-4°

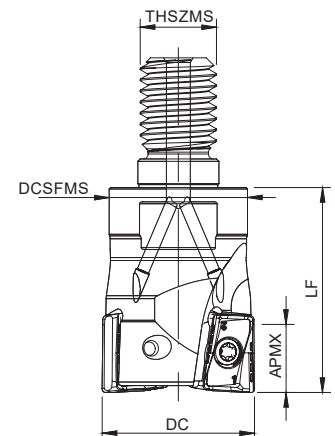

Order code Código	Reference Referência Referencia	CICT	Dimensions Dimensões Dimensiones (mm)				WT	Specifications	Insert Pastilha Inserto	Stock
			DC	THSZMS	DCSFMS	LF		APMX (mm)		
181082800	032R18190-02-04-M16043	2	32	M16	29	43	0,20	15,0	ANHX 1607...	☺
181082900	040R18190-03-04-M16043	3	40	M16	29	43	0,24	15,0	ANHX 1607...	☺

☺ Stock item | Produto de stock | Itens de stock

○ Available under request | Disponível sobre consulta | Disponible bajo consulta

PLUS 18190
ANHX 16

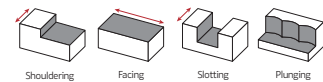

Weldon Shank
KAPR=90° | GAMP=-4°

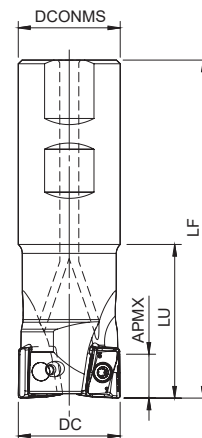

Order code Código	Reference Referência Referencia	CICT	Dimensions Dimensões Dimensiones (mm)				WT	Specifications	Insert Pastilha Inserto	Stock
			DC	DCONMS	LF	LU		APMX (mm)		
181051600	032W18190-02-04-032110	2	32	32	110	50	0,66	15,0	ANHX 1607...	⊗
181067500	040W18190-03-04-032115	3	40	32	115	40	0,66	15,0	ANHX 1607...	⊗

⊗ Stock item | Produto de stock | Itens de stock

○ Available under request | Disponível sobre consulta | Disponible bajo consulta

ANHX 1607... Inserts | Pastilhas | Plaquetas



ANHX-LP



ANHX-MP



ANHX-LN

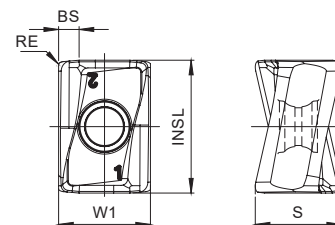

ANHX-LP | MP | LN

Geometry code	ISO Reference	P								K						N	Dimensions Dimensões Dimensiones (mm)				
		CVD		PVD						CVD		PVD				UNC	W1	S	INSL	RE	BS
		T9	G1	X5	G4	T1	P3	P4	T9	G1	X5	G4	T1	P3	P4	10					
1111519	ANHX 160708 PNR-LP		△	○		⊗	△	⊗		△	○		⊗	△	⊗		11,20	10,80	16,00	0,80	1,40
1111596	ANHX 160712 PNER-LP			○		⊗		⊗			○		⊗		⊗		11,20	10,50	16,00	1,20	1,20
1111595	ANHX 160708 PNER-MP	⊗	△	○		⊗		⊗	⊗	△	○		⊗		⊗		11,20	10,80	16,00	0,80	1,40
1111598	ANHX 160712 PNER-MP			○		⊗		⊗			○		⊗		⊗		11,20	10,50	16,00	1,20	1,20
1111659	ANHX 160708 PNFR-LN														⊗		11,20	10,80	16,00	0,80	1,40
1111597	ANHX 160712 PNFR-LN														⊗		11,20	10,50	16,00	1,20	1,20

⊗ First choice | 1ª Escolha | 1ª Opción

△ Stock available until sold out | Stock disponível até acabar o stock | Stock disponible hasta acabar el stock

Insert Order Code: ⁽¹⁾ Geometry code + ⁽²⁾ Grade code

⊗ Stock items | Itens de stock

○ Available under request | Disponível sobre consulta | Disponible bajo consulta

SPARE PARTS Acessórios | Repuestos

Cutter DC	Insert Screw	Key (Torx)	Order separately		Order separately	
			Key (Torx - Nm)	Torque Value	Screw	DIN 6368 Wrench
W18190 - 32 - 40	P0401200	XT15	DT1530	3,0	-	-
R18190 - 32 - 40	P0401200	XT15	DT1530	3,0	-	-
A18190 - 50 - 63	P0401200	XT15	DT1530	3,0	-	-
A18190 - 80	P0401200	XT15	DT1530	3,0	J0123510	SD6368-12
A18190 - 100	P0401200	XT15	DT1530	3,0	J0164110	SD6368-16
A18190 - 125	P0401200	PT15	DT1530	3,0	J0204610	SD6368-20
A18190 - 160	P0401200	PT15	DT1530	3,0	-	-

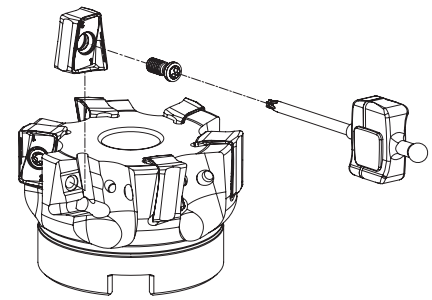

RECOMMENDED CUTTING CONDITIONS Condições de corte recomendadas | Condiciones de corte recomendables

ISO	PSM	Material	HB (Brinell)	Vc (m/min)							Feed fz (mm/t)		
				← Wear Resistance				Toughness →					
				PH0910	PH7910	PHP920	PH7920	PHP930	PH7930	PHS740	ANHX 12.. LP	ANHX 12.. MP	ANHX 12.. LN
P	1	Unalloyed Steel	125-220	-	180-250	180-250	180-240	160-230	160-220	140-220	0,10-0,25	0,10-0,25	-
	2	Low-Alloyed Steel	220-280	-	160-230	160-230	160-220	140-210	140-200	120-200	0,10-0,25	0,10-0,25	-
	3	High-Alloyed Steel	280-380	-	140-220	140-220	140-210	120-200	120-190	100-190	0,10-0,20	0,10-0,20	-
K	7	Malleable Cast Iron	130-230	-	180-300	160-270	160-260	150-250	150-240	160-300	0,10-0,25	0,10-0,25	-
	8	Grey Cast Iron	180-245	-	160-250	140-250	140-240	140-230	140-230	150-260	0,10-0,25	0,10-0,25	-
	9	Nodular Cast iron	160-250	-	150-200	120-210	120-200	100-200	100-190	80-220	0,10-0,20	0,10-0,25	-
N	10	Aluminium and Non Ferrous	30-130	100-2000	-	-	-	-	-	-	-	-	0,10-0,40

(Note 1)
Cutting conditions $a_e/D_c=70\%$.

(Note 2)

Operation	a_e	Vc & fz	AP (mm)
Slotting	100%	<20%	2,5-4,5
Shouldering	<50%	>8%	6,0-8,0
	≤25%	>12%	8,0-15,0

(Note 3)

It's possible to occur vibrations in certain cases. Please reduce depth of cut and / or reduce cutting conditions in following cases:

- When using long shank;
- When using long tool overhang with arbor type;
- When application has poor clamping rigidity or when using a low rigidity machine.

GRADES SELECTION GUIDE Guia para selecção de graus | Tabla para selección de calidades

ISO	PSM	Material	HB (Brinell)	Grades						
				← Wear Resistance				Toughness →		
				PH0910	PH7910	PHP920	PH7920	PHP930	PH7930	PHS740
P	1	Unalloyed Steel	125-220	●	●	●	●	●	●	●
	2	Low-Alloyed Steel	220-280		●	●	●	●	●	●
	3	High-Alloyed Steel	280-380		●	●	●	●	●	●
K	7	Malleable Cast Iron	130-230		●	●	●	●	●	●
	8	Grey Cast Iron	180-245		●	●	●	●	●	●
	9	Nodular Cast iron	160-250		●	●	●	●	●	●
N	10	Aluminium and Non Ferrous	30-130	✓						

● Good Conditions

● Average Conditions

● Difficult Conditions

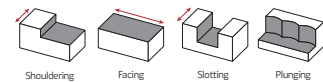

CHIP BREAKER SELECTION GUIDE Guia para aplicações do quebra- aparas | Guía para aplicación del rompevirutas

ISO	PSM	Material	HB (Brinell)	Chip breaker application	
				1 st choice	Difficult Operations
P	1	Unalloyed Steel	125-220	ANHX 16... LP	ANHX 16... MP
	2	Low-Alloyed Steel	220-280	ANHX 16... LP	ANHX 16... MP
	3	High-Alloyed Steel	280-380	ANHX 16... LP	ANHX 16... MP
K	7	Malleable Cast Iron	130-230	ANHX 16... LP	ANHX 16... MP
	8	Grey Cast Iron	180-245	ANHX 16... LP	ANHX 16... MP
	9	Nodular Cast iron	160-250	ANHX 16... LP	ANHX 16... MP
N	10	Aluminium and Non Ferrous	30-130	ANHX 16... LN	-

PLUNGING Mergulho | Plunge

L < 3DC	L > 3DC	S max.
f _z (mm/t)		
0,10-0,20	0,10-0,14	$S_{max} = \sqrt{DC \cdot DR - DR^2}$

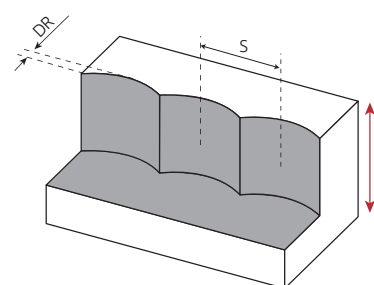

S max and DR corresponding cutting diameter DC (mm)								
DR (mm)	DC (mm)							
	32	40	50	63	80	100	125	160
1,0	5,6	6,2	7,0	7,9	8,9	9,9	11,1	12,6
2,0	7,7	8,7	9,8	11,0	12,5	14,0	15,7	17,8
3,0	9,3	10,5	11,9	13,4	15,2	17,1	19,1	21,7
4,0	10,6	12,0	13,6	15,4	17,4	19,6	22,0	25,0
5,0	11,6	13,2	15,0	17,0	19,4	21,8	24,5	27,8

18190 - TEST REPORT Relatório de Teste | Informe de Prueba

<p>Milling cutter 063A18190-06-04-022040</p> <p>Insert ANHX 160708-PNER-LP</p> <p>Grade PH7920</p> <p>22% productivity improvement</p> <p>Machining time 55 (min/per edge)</p>	<p>Milling cutter Competitor Equivalent product</p> <p>Insert Competitor Equivalent product</p> <p>Grade Competitor Equivalent product</p> <p>Machining time 40 (min/per edge)</p>
--	--



Work material: EN-JL 1040 (0.6025)

Cutting speed: Vc (m/min)	220
Feed per tooth: fz (mm/t)	0,18
Depth of cut: ap (mm)	8
Width of cut: ae (mm)	20
Method of machining	Shoulder milling
Coolant	Dry

17190 - TEST REPORT Relatório de Teste | Informe de Prueba

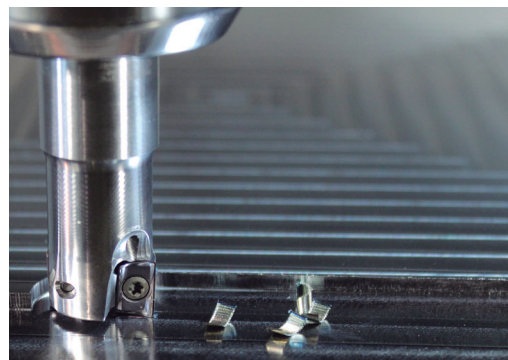

Work material: 40CrMnNiMo8 (1.2738) - (34-38 HRC)

Cutting speed: Vc (m/min)	180
Feed per tooth: fz (mm/t)	0,2
Depth of cut: ap (mm)	3
Width of cut: ae (mm)	12
Method of machining	Shoulder milling
Coolant	Dry

17590 - TEST REPORT Relatório de Teste | Informe de Prueba

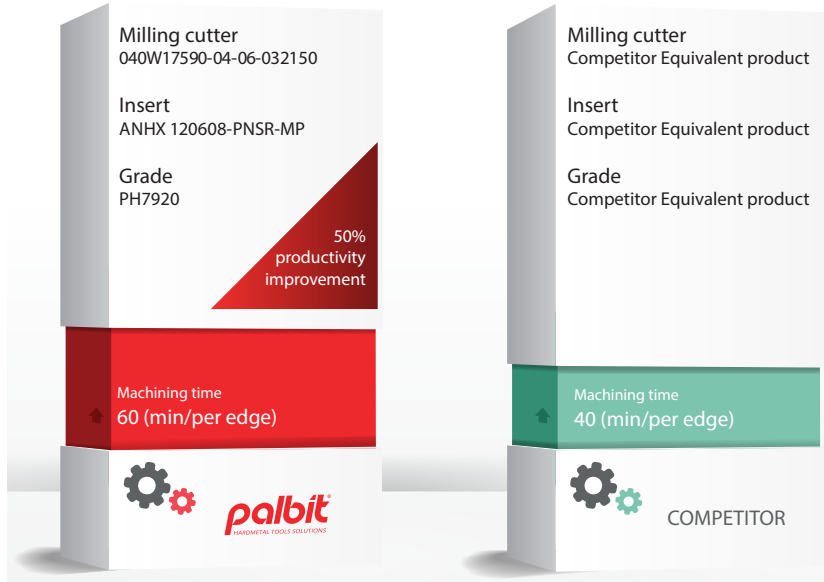

Work material: 40CrMnNiMo8 (1.2738) - (34-38 HRC)

Cutting speed: Vc (m/min)	200
Feed per tooth: fz (mm/t)	0,18
Depth of cut: ap (mm)	5
Width of cut: ae (mm)	30
Method of machining	Shoulder milling
Coolant	Dry



HEADQUARTERS

PALBIT. S.A.
 T (+351) 234 540 300 | F (+351) 234 540 301
 palbit@palbit.pt | www.palbit.pt

Branch office

PALBIT México, S de RL de CV
 T (+52) 5555 454 543 | F (+52) 5552 509 190
 info@palbit.com.mx | www.palbit.pt/mx

Branch office

PALBIT Brasil
 T (+55) 011 25 343 648
 palbit@palbit.com.br | www.palbit.pt/br